

SECTION OF COLUMN

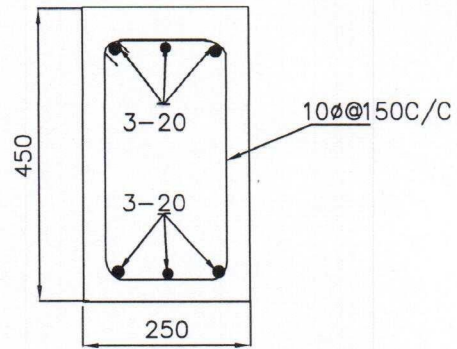

SECTION OF BRACE

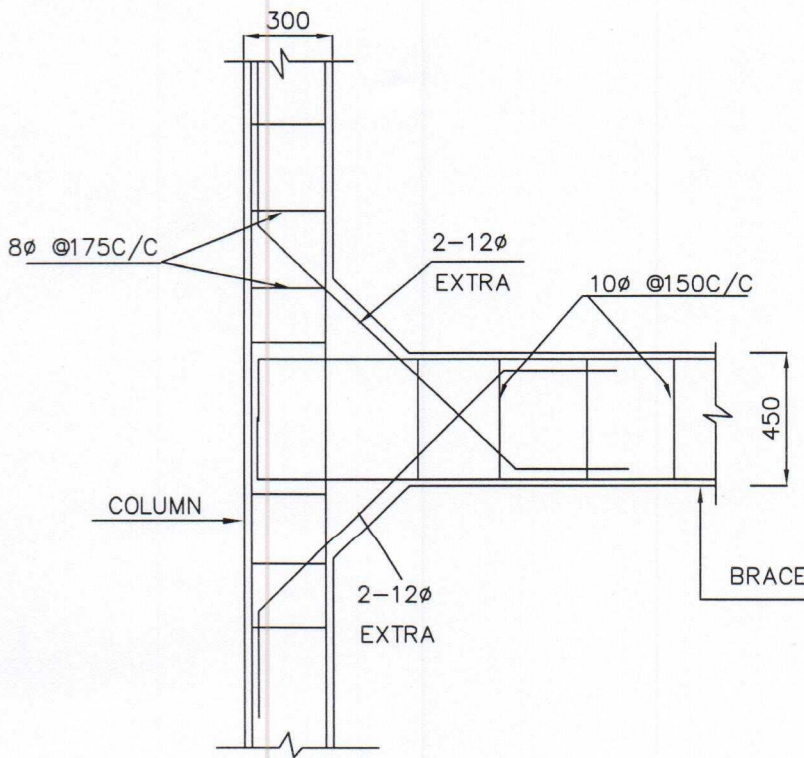

COLUMN BRACE JUNCTION

|| APPROVED ||

CE-I
 CE-II
 CE-III
 TDWSP, Hyderabad
 2014
 2014
 2014
 2014

| | |
|---|---------------|
| Government of Telangana. | |
| Rural Water Supply & Sanitation Department | |
| Construction of 120 KL capacity OHSR/OHBR 12m staging column type | |
| Scale: Not to scale | sheet: 2 of 8 |

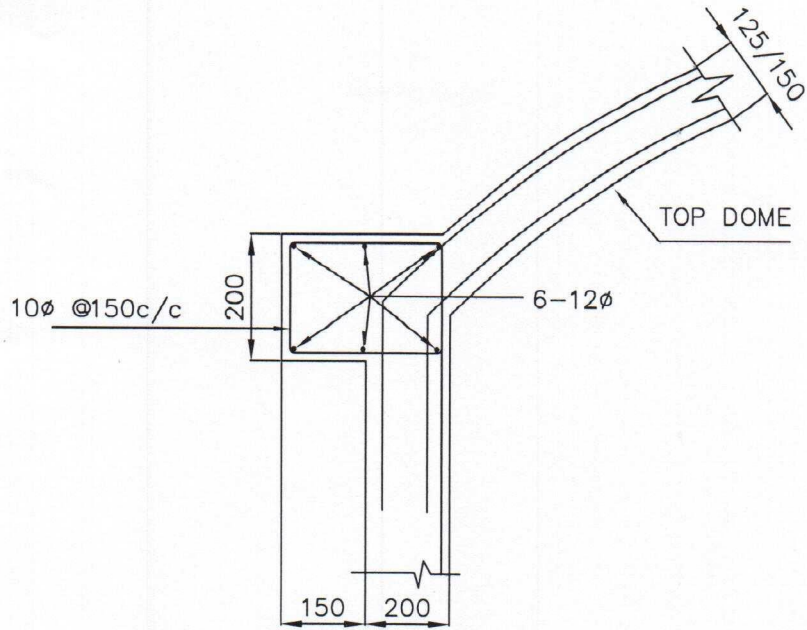

DETAILS OF TOP DOME RING BEAM

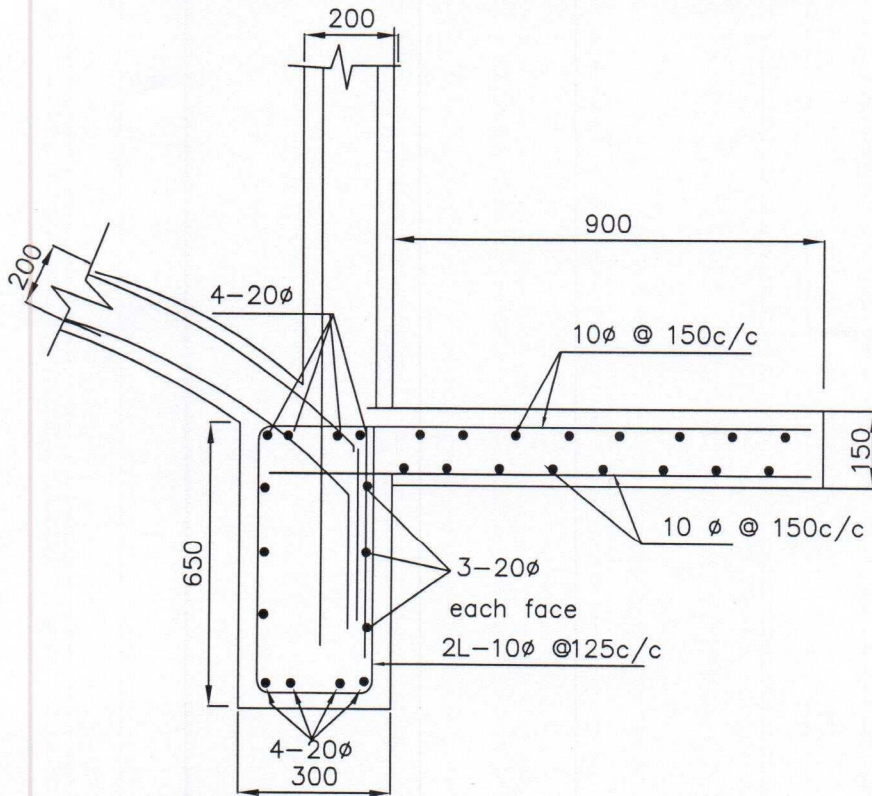

BOTTOM RING BEAM CUM LANDING

|| APPROVED ||

CE-1 *G. V. Rao* 2014
 CE-II *P. J. 21/4/17*
 CE-III
 TDWSP, Hyderabad
 2014 2014 2014 2014/2014

| | |
|---|---------------|
| Government of Telangana. | |
| Rural Water Supply & Sanitation Department | |
| Construction of 120 KL capacity OHSR/OHBR 12m staging column type | |
| Scale: Not to scale | sheet: 3 of 8 |

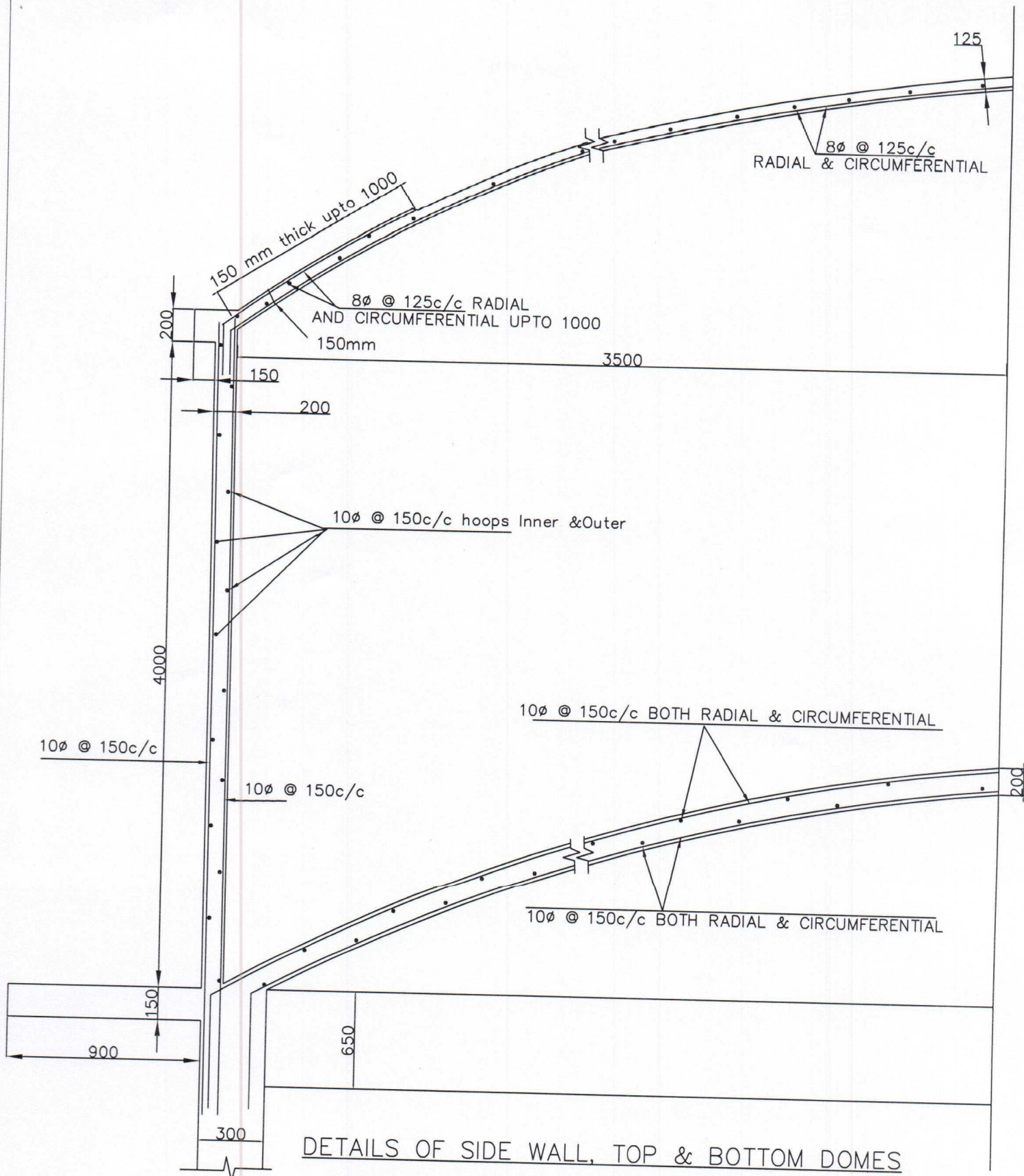

DETAILS OF SIDE WALL, TOP & BOTTOM DOMES

11 APPROVED 11

CE-I
20/4/17

CE-II
20/4/17

CE-III
20/4/17

TOWSP, Hyderabad

20/4/17

20/4/17

20/4/17

| | |
|---|---------------|
| Government of Telangana. | |
| Rural Water Supply & Sanitation Department | |
| Construction of 120 KL capacity OHSR/OHBR 12m staging column type | |
| Scale: Not to scale | sheet: 4 of 8 |

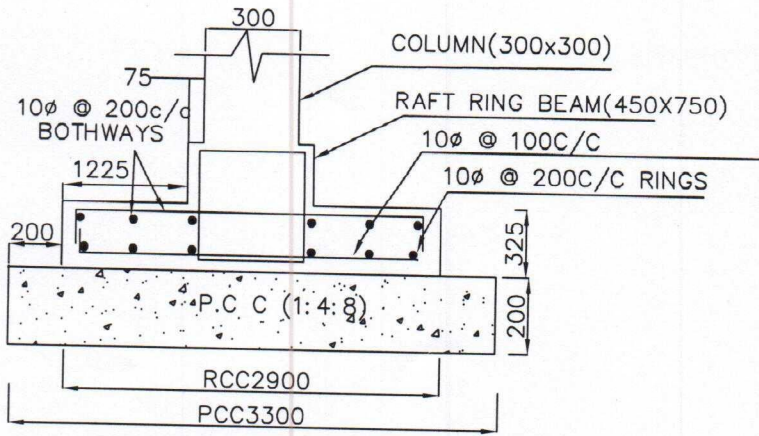

SECTION A-A

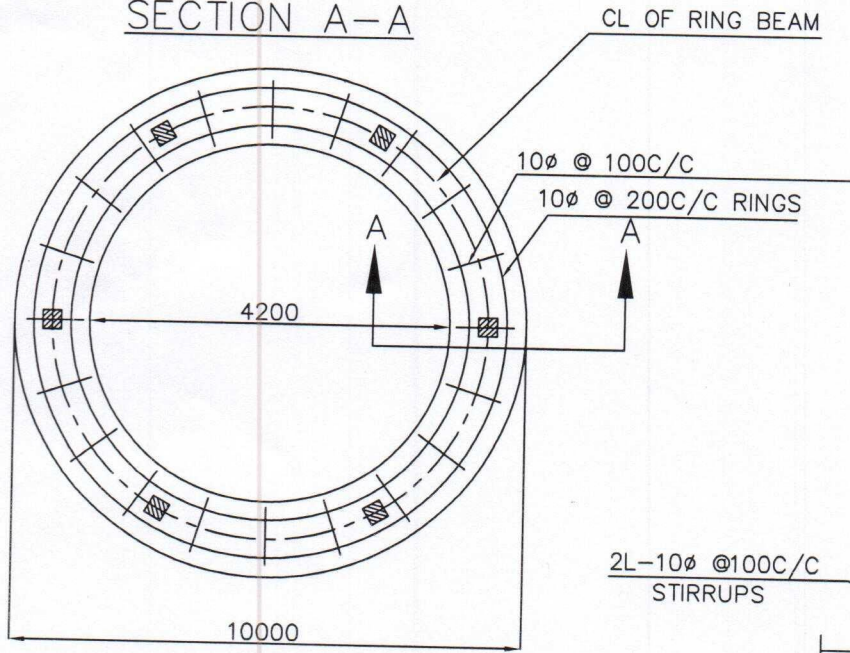

BOTTOM REINFORCEMENT OF RING FOUNDATION
SBC 7.5t/M²

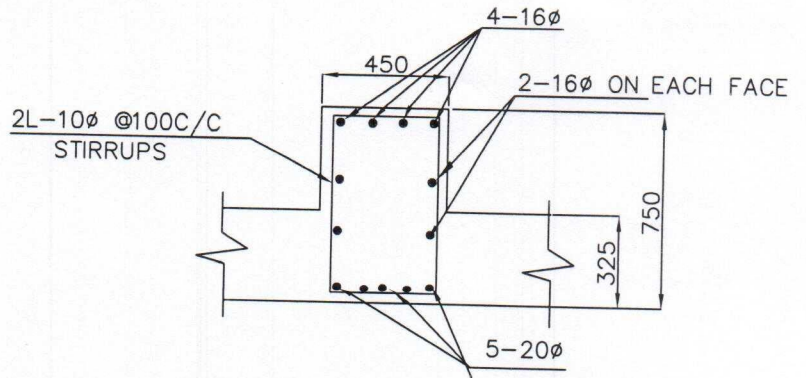

SECTION OF RAFT RING BEAM

II APPROVED U

CE-I
Gimmed 20/4
CE-II
Rajesh 20/4
CE-III
Rajesh 20/4

TDWSP, Hyderabad

20/4
Rajesh 20/4
20/4
20/4/2017

| | |
|---|---------------|
| Government of Telangana. | |
| Rural Water Supply & Sanitation Department | |
| Construction of 120 KL capacity OHSR/OHBR 12m staging column type | |
| Scale: Not to scale | sheet: 5 of 8 |

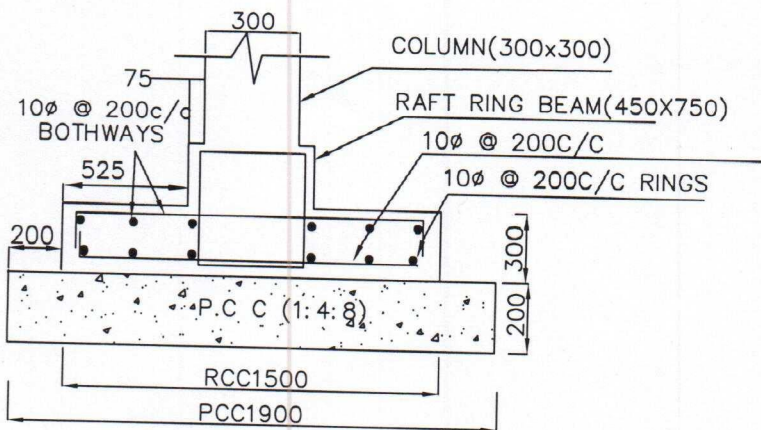

SECTION A-A

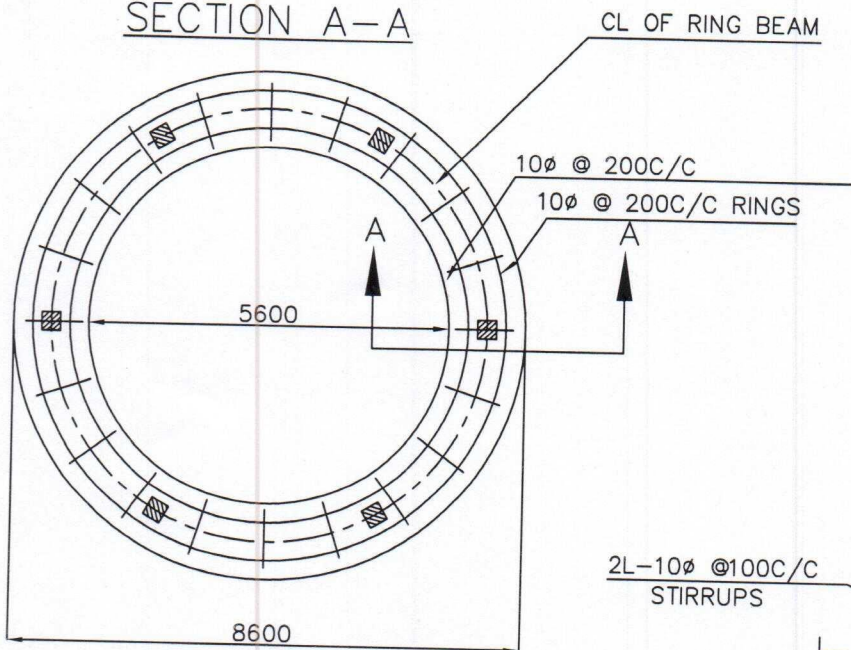

BOTTOM REINFORCEMENT OF RING FOUNDATION
SBC 15t/M2

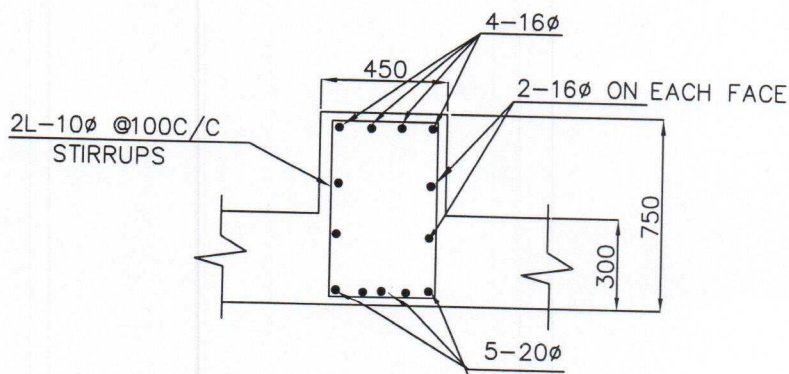

SECTION OF RAFT RING BEAM

|| APPROVED ||

CE-I ✓
CE-II
CE-III

TDWSP, Hyderabad

20/14
20/14
20/14
20/14/2017

| | |
|---|---------------|
| Government of Telangana. | |
| Rural Water Supply & Sanitation Department | |
| Construction of 120 KL capacity OHSR/OHBR 12m staging column type | |
| Scale: Not to scale | sheet: 6 of 8 |

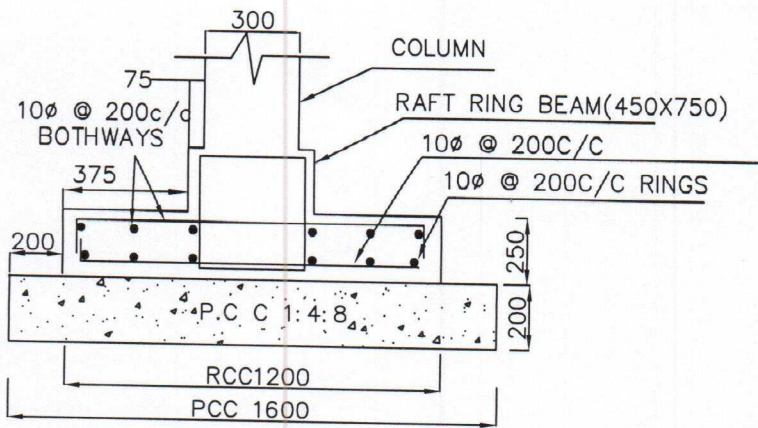

SECTION A-A

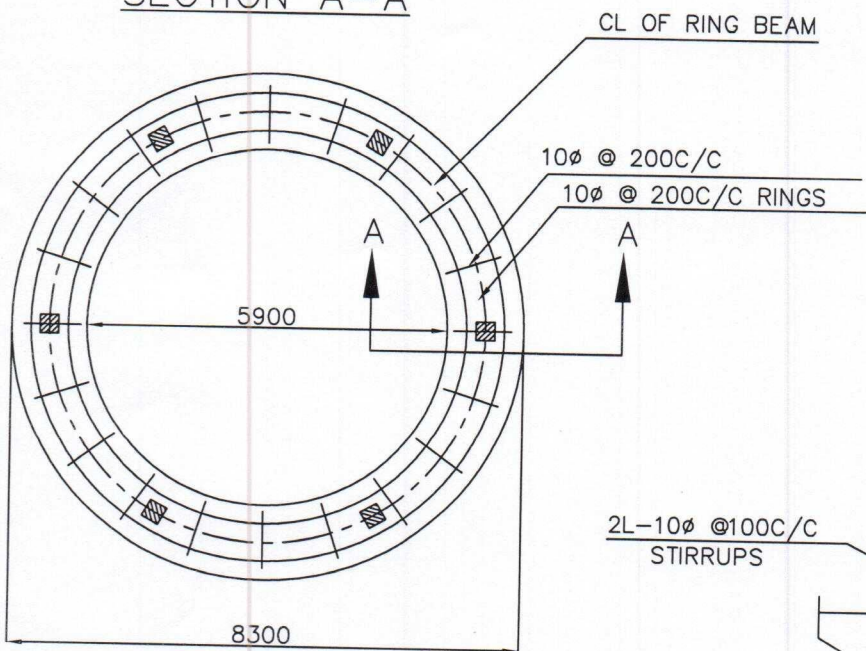

BOTTOM REINFORCEMENT OF RING FOUNDATION
SBC 20t/M²

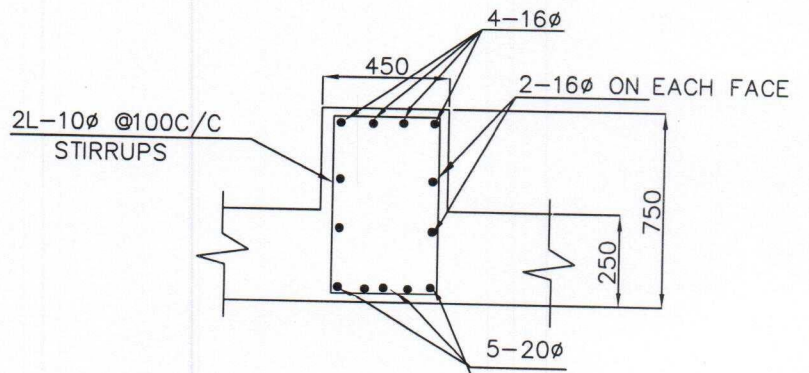

SECTION OF RAFT RING BEAM

|| APPROVED ||

CE-I
CE-II
CE-III

T D W S P, Hyderabad

20/4
20/4
20/4
20/4

| | |
|---|---------------|
| Government of Telangana. | |
| Rural Water Supply & Sanitation Department | |
| Construction of 120 KL capacity OHSR/OHBR 12m staging column type | |
| Scale: Not to scale | sheet: 7 of 8 |

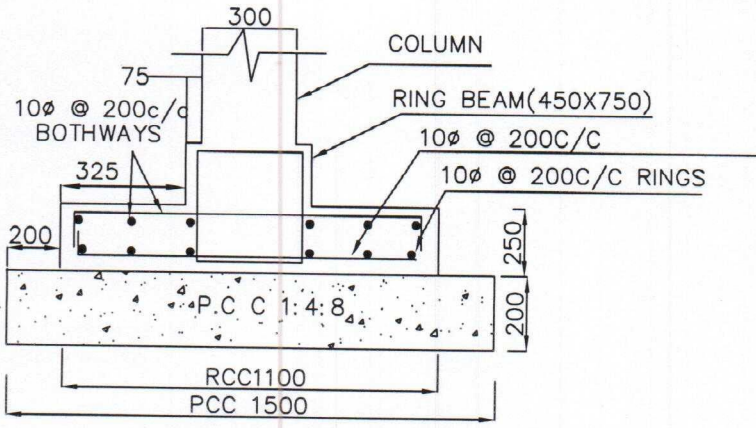

SECTION A-A

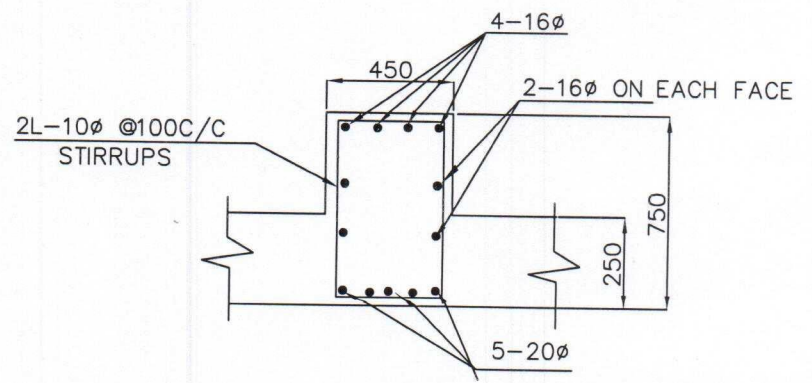
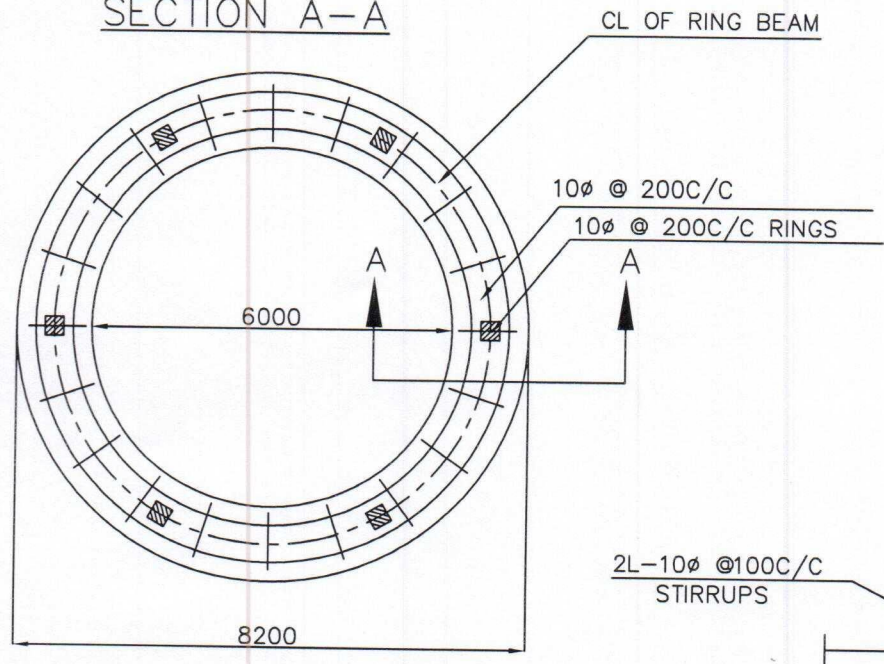

SECTION OF RAFT RING BEAM

BOTTOM REINFORCEMENT OF RING FOUNDATION
SBC 30t/M2

!! APPROVED !!

CE-1
 G. V. Reddy 2014
 CE-II
 P. Jayaram 2014
 CE-III
 TDWSP, Hyderabad
 2014
 2014
 2014
 2014/2017

| | |
|---|---------------|
| Government of Telangana. | |
| Rural Water Supply & Sanitation Department | |
| Construction of 120 KL capacity OHSR/OHBR 12m staging column type | |
| Scale: Not to scale | sheet: 8 of 8 |